

St. Mary's Youth Soccer Training Series

Topic: 1st Defender
Age/Level: ALL
Type:

→ Run Pass ●-▲ Dribble



Notes: This session is designed to progress the players understanding on 1v1 defending. Gradually the player will learn how to be patient, smart and solid as a defender.

Session provided by: Jack Greely

Progression: 1 (Warm-up)
 Exercise: Column Drill
 Time: 10 Minutes

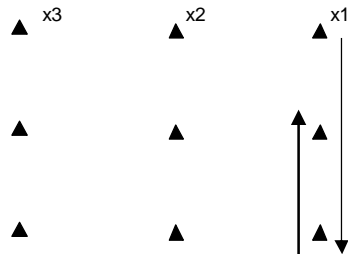

Set up three columns of cones ~ 5 yds apart, & 3 rows of cones ~ 8 yds. Apart. You will break Your team into 3 lines to start exercises. The Leader of each line will have their group on the Left side of the first cone and will call each exercise To their group as they go thru the warm-up.

1. Jog down left side around last cone come back On rt. Side (3x)
2. Side shuttle down Swing arms across & job back (3x)
3. Karioke down, & jog back(3x)
4. High skip down, jog back(3x)
5. Low skip down, jog back(3x)
6. High inside/outside leg rotation (like throwing Leg over short fence)(3x)
7. Opposite of 6 outside to inside (3x)
8. Jog 1st cone, sprint 2nd cone(3x)
9. Fast feet in place, lean slightly forward, sprint To first cone, jog to second(3x)

****Stretch as team in between each warm up progression**

Progression: 1a & 1b
 Exercise: 4v2 games
 Time: 15 Minutes

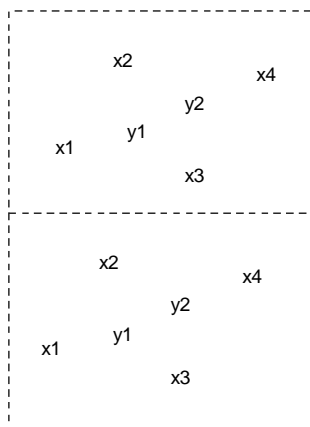

1a). Setup small grids ~ 10 x 20 and arrange your players as 4 attackers, 2 defenders. By using two defenders during warm up you are getting the kids in the right mind set for the upcoming session. Don't really need to do any coaching at this point, just remind defenders to put pressure on the ball as it will be a key factor for the session.

1b). Quick feet exercises, toe taps, inside foot taps... and stretching

Progression: 3
 Exercise: 1v1
 Time: 30 Minutes

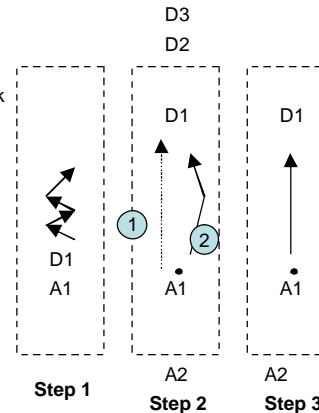

Step 1 Step 2 Step 3

STEP 1 - Shadow defend w/no ball in pairs ~ 20 yards and switch. Emphasis on stance low, knees bent, shuffle feet. 10 minutes

STEP 2 - Split a 20x20 grid into 4 columns (5x20) and split the team into four groups. Once these teams are established split the group in half and place on either end of the grid. The ball will start at a designated end, once a player has passed the ball across the grid he becomes the defender and the player with the ball becomes the attacker. This will continue until a good level of quality defending has been reached. 10 minutes

STEP 3 - On five minute intervals, the lone defender must try and defend the attacker. As soon as the play has broken down, the next attacker should go. After five minutes the defender will change and another player will become that defender. Do this until a full cycle has occurred.

IMPORTANT – Defenders must use appropriate defending methods stance, closing distance, position, approach, force direction...

Progression: 3a & 3b
 Exercise: 4v2 & 4v4
 Time: 40 Minutes

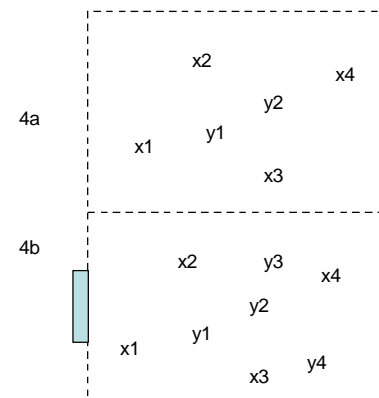

4a). Using the grid you set up for warm up, play 4v2 again, now really emphasis the 1st def. role.

4b). Now expand the grids based on age of players and play 4v4 with goals. Points made during the game should still focus on 1st def. Make sure to paint the picture for all to see both positive and negative on how the 1st def. takes care of pressure on the ball.